

**PLAN**

ALL JOINTS SHALL BE RESTRAINED. FITTINGS: MEGALUG RESTRAINTS, OR EQUAL PIPE BELLS: FIELD LOK GASKETS, OR EQUAL

\*\* REQUIRED FOR ALL METALLIC PIPE INSTALLATIONS

APPROVED FITTINGS	
DESCRIPTION	MUELLER
INSULATED CORP. STOP (MIP x COMP)	N-35028
CURB STOP (COMP x COMP)	B-25209
90° BEND (COMP x MIP)	H-15531

\*\* SHALL BE INSULATED FITTINGS BY MUELLER OR JONES

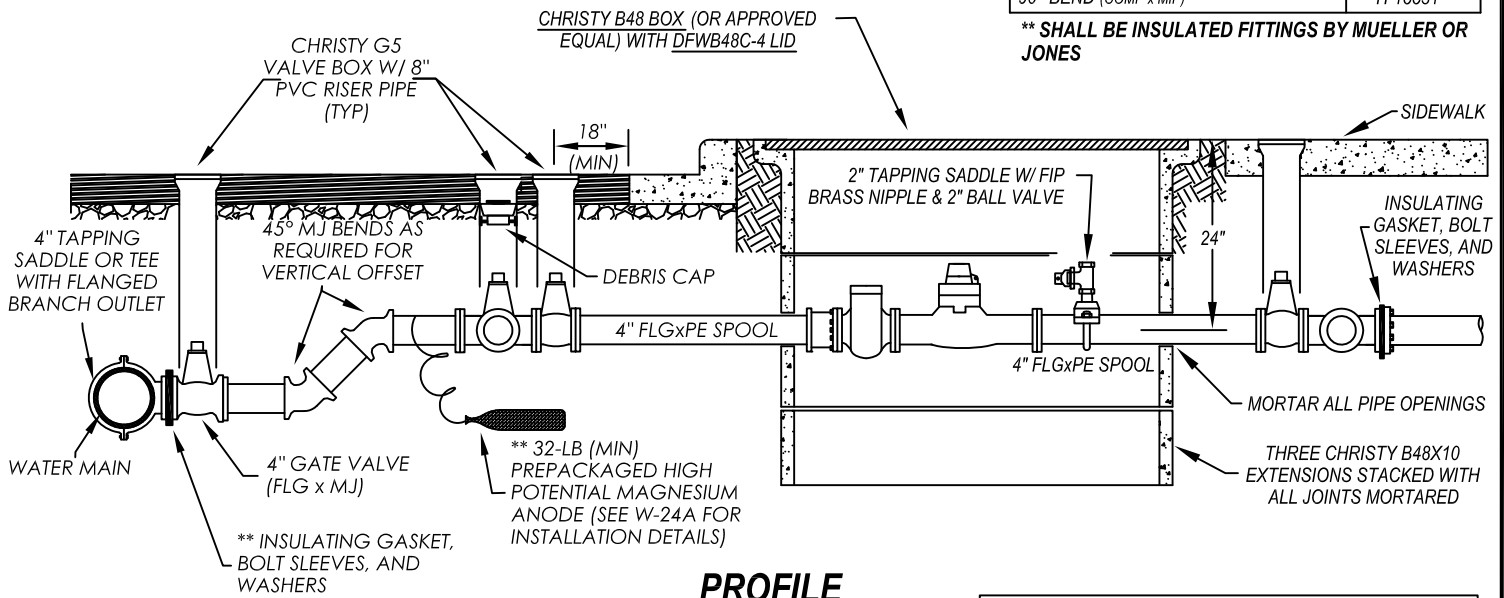

**PROFILE**

FLANGETYTE GASKETS BY U.S. PIPE SHALL BE USED FOR ALL FLANGED FITTINGS. INSULATING GASKETS SHALL BE TYPE E 1/8" THICK FULL-FACED NEOPRENE PHENOLIC GASKETS INSTALLED WITH GRADE G-10 FIBERGLASS EPOXY INSULATING BOLT SLEEVES AND WASHERS.

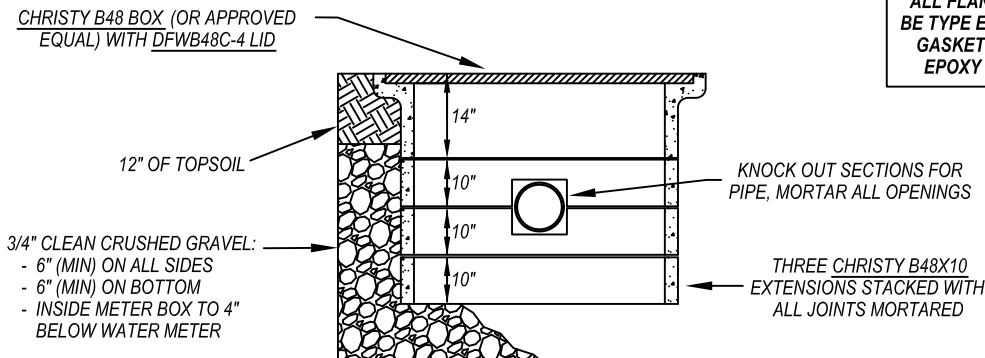

**DETAIL**

METER BOX INSTALLATION

ALTERNATE MATERIALS MUST BE APPROVED BY THE CITY OF NAPA WATER DIVISION PRIOR TO USE

CITY OF NAPA

PUBLIC WORKS DEPARTMENT

TITLE  
**4" WATER SERVICE**

DRAWN BY:	DCF	CHECKED BY:	MJH
DATE:	09/2019	APPROVED BY:	MJH
SCALE:	NTS	DRAWING NO.	W-3B.1
FIELD NOTES:			

**NOTES**

1. METER BOX AND SERVICE LINE SHALL BE INSTALLED 3-FT (MIN) OUTSIDE OF DRIVEWAY, DRIVEWAY APPROACHES, AND OTHER VEHICULAR ACCESS WAYS.
2. SERVICE LATERAL (FROM WATER MAIN TO TEE AT METER/BYPASS SPLIT) SHALL BE 4-INCH C900 PVC OR CLASS 350 DUCTILE IRON PIPE.
3. METER, ISOLATION GASKET (FOR METER ONLY), BOLT SLEEVES AND WASHERS ARE PROVIDED BY CITY OF NAPA AFTER PAYMENT OF METER SET FEE AND INSTALLED BY CONTRACTOR.
4. ALL BURIED SECTIONS OF METALLIC PIPE AND FITTINGS SHALL BE WRAPPED WITH AN 8-MIL POLYETHYLENE WRAP, WITH THE EXCEPTION OF COPPER PIPE AND BRASS FITTINGS WHICH SHALL BE WRAPP 8-MIL PLASTIC SLEEVE. COPPER PIPE NOT WRAPPED IN A PLASTIC SLEEVE SHALL BE NSF 61 APPROVED PLASTIC COATED COPPER TUBING (TYPE "K", BLUE IN COLOR). ALL BURIED INSULATED GASKETS SHALL BE WRAPPED WITH 10-MIL HIGH TACK PIPE WRAP TAPE 3-FT (MIN) TO EACH SIDE OF THE INSULATION POINTS.
5. EXISTING WATER MAINS SHALL BE HOT-TAPPED BY CITY FORCES AT DEVELOPER'S EXPENSE. HOT-TAP INCLUDES SADDLE, VALVE, G5 BOX, PVC RISER, AND MISCELLANEOUS FITTINGS. SEE W-16 FOR HOT-TAP REQUIREMENTS. HOT TAPS SHALL BE 36-IN (MIN) FROM ANY TAP, BELL, FITTING, OR OTHER SERVICE.
6. A TEE AND 4-INCH GATE VALVE SHALL BE INSTALLED INSTEAD OF A HOT-TAP WHEN THE EXISTING WATER MAIN IS 4-INCHES IN DIAMETER, OR WHEN IT IS INSTALLED AS PART OF A NEW WATER MAIN INSTALLATION. 4-INCH WATER SERVICES SHALL NOT BE INSTALLED ON WATER MAINS SMALLER THAN 4-INCHES IN DIAMETER.
7. APPROVED BACKFLOW PREVENTION DEVICES SHALL BE INSTALLED AND TESTED, AND WATER METERS SHALL BE SET, PRIOR TO ANY USE OF WATER SERVICE. USE OF JUMPERS, HOSE BIBS, OR OTHER DEVICES SHALL NOT BE PERMITTED.
8. METERS SHALL BE PLACED A MINIMUM OF 3-FT FROM ANY OBSTRUCTION (SIGN POST, MAIL BOX, FENCES, WALLS, ETC.). NO TREES SHALL BE PLANTED WITHIN 10-FT OR LARGE SHRUBS WITHIN 5-FT OF THE METER BOX. SEE W-18 FOR ADDITIONAL REQUIREMENTS.
9. SERVICES SHALL BE SIZED APPROPRIATELY FOR THE INTENDED USE OF THE SERVICE. WATER DIVISION MAY REQUEST AN ENGINEERED WATER ANALYSIS OF THE SYSTEM (NEW OR EXISTING) TO EVALUATE THE APPROPRIATENESS OF THE WATER SERVICE SIZE. NO UNDERSIZED WATER SERVICES SHALL BE PERMITTED.
10. BYPASS SIZE MAY BE MODIFIED TO MATCH THE SERVICE SIZE UPON APPROVAL OF THE WATER DIVISION ENGINEER.

CITY OF NAPA

PUBLIC WORKS DEPARTMENT

TITLE  <b>4' WATER SERVICE</b>	DRAWN BY: DCF	CHECKED BY: MJH
	DATE: 09/2019	APPROVED BY: MJH
	SCALE: NTS	DRAWING NO. W-3B.2
	FIELD NOTES:	