

3/4" TO 2" SERVICES WITH CORPORATION STOPS

TEE OR TAPPING SADDLE

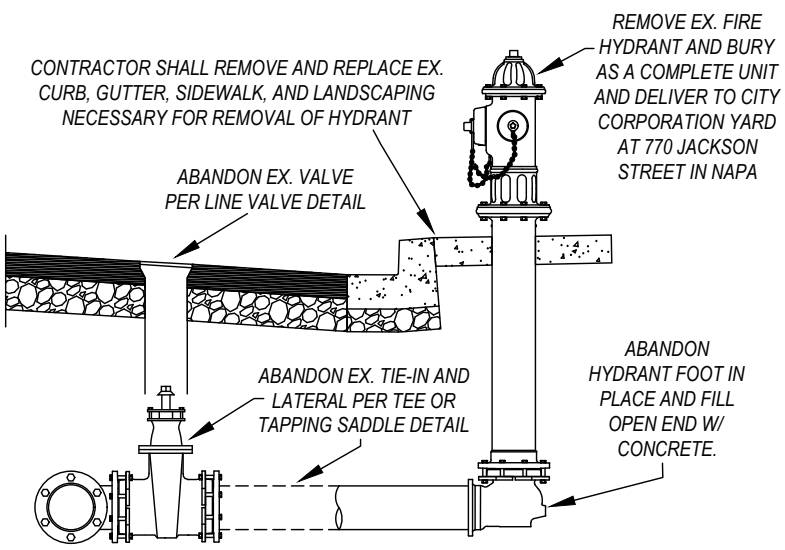
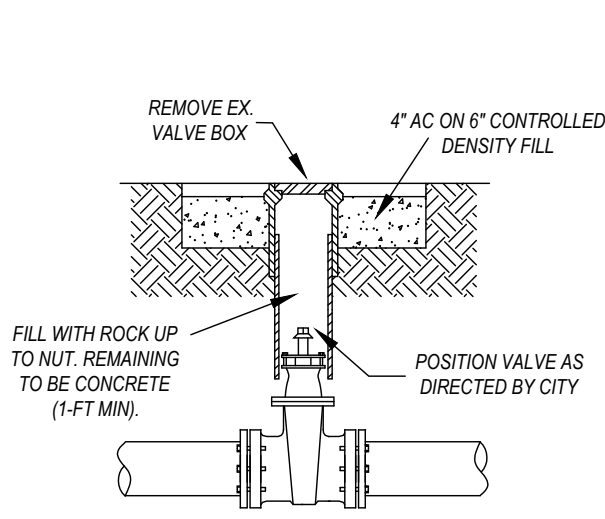

LINE VALVE

FIRE HYDRANT

NOTES

1. ALL ABANDONMENT WORK SHALL BE UNDER THE DIRECT SUPERVISION OF THE WATER DIVISION INSPECTOR. THE CONTRACTOR IS RESPONSIBLE FOR NOTIFYING WATER CUSTOMERS AFFECTED BY A WATER SHUT-OFF A MINIMUM OF 48 HOURS (2 WORKING DAYS) IN ADVANCE. CITY PERSONNEL SHALL OPERATE EXISTING VALVES ON THE WATER SYSTEM. CONTRACTOR TO PROVIDE A MINIMUM OF 48 HOUR (2 WORKING DAYS) NOTICE FOR CITY PERSONNEL BY CALLING 707-257-9544 TO SCHEDULE SHUTDOWN.
2. WATER SERVICES LARGER THAN 2" REQUIRE REMOVAL OF THE TEE OR TAPPING SADDLE AT THE MAIN AS SHOWN ABOVE AND REMOVAL OF METER BOX. CONTACT WATER DIVISION TO CLOSE ACCOUNT AND PICK-UP METER.
3. WATER MAINS REQUIRE ABANDONMENT OF THE TEE OR TAPPING SADDLE AS SHOWN ABOVE. CONTRACTOR IS RESPONSIBLE FOR RELOCATING AND RECONNECTING EXISTING WATER SERVICES TO AN ACTIVE WATER MAIN AT THE DIRECTION OF WATER DIVISION STAFF.
4. WHEN WATER FACILITIES ARE REMOVED (INCLUDING BUT NOT LIMITED TO WATER METERS AND FIRE HYDRANTS), CONTRACTOR SHALL BACKFILL HOLE WITH CONCRETE (PER S-4) IF HOLE IS LOCATED WITHIN SIDEWALK SECTION, ASPHALT (PER W-13A) IF HOLE IS LOCATED WITHIN STREET SECTION, OR SOIL COMPACTED TO 90% IF HOLE IS LOCATED WITHIN A LANDSCAPE STRIP, AS DETERMINED BY THE WATER DIVISION.

CITY OF NAPA

UTILITIES DEPARTMENT

TITLE	ABANDONMENT OF EXISTING WATER FACILITIES	
DRAWN BY:		DF
APPROVAL DATE:		09/2021
SCALE:		NTS
REVISED DATE:	09/2021	

CHECKED BY:	SL
APPROVED BY:	DD
DRAWING NO.	W-17