

HORIZONTAL INSTALLATION

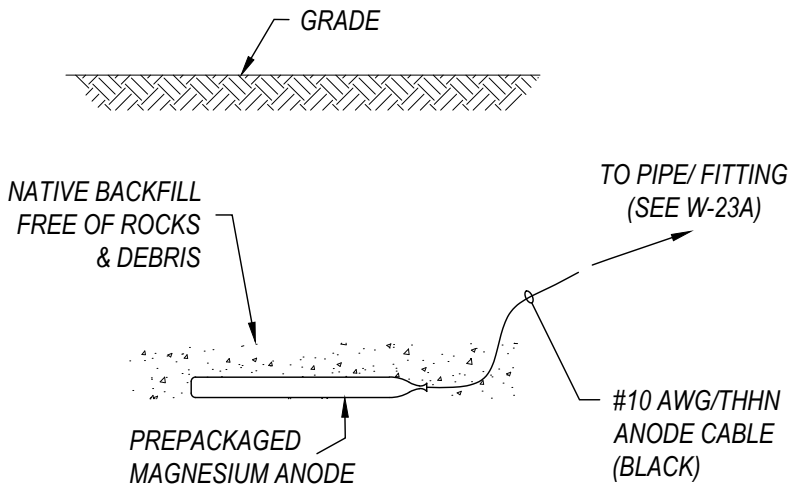

VERTICAL INSTALLATION

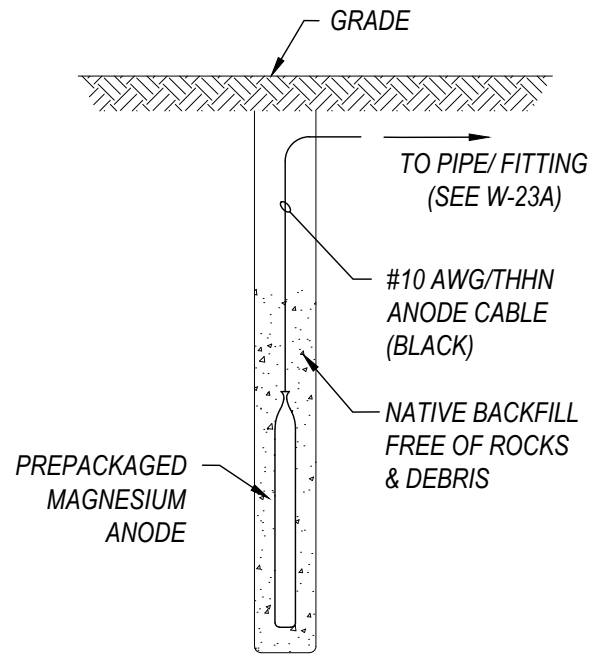

NOTES

1. ANODE INSTALLATION REQUIRED ON NON EPOXY COATED FITTINGS, NEW DUCTILE IRON PIPE INSTALLATION, AND AS PART OF NEW CONNECTIONS TO EXISTING DUCTILE IRON PIPE. INSTALL ANODES WITH 3-FT SEPARATION FROM THE PIPE/FITTING IN NATIVE SOIL.
2. ANODES MAY BE INSTALLED HORIZONTALLY OR VERTICALLY, UNLESS SPECIFICALLY DIRECTED BY THE WATER DIVISION.
3. A MINIMUM DISTANCE OF 10-FT SHALL BE MAINTAINED BETWEEN MULTIPLE ANODES.
4. ANODES SHALL BE INSTALLED A MINIMUM OF 3-FEET FROM ALL SEWER AND STORM DRAIN FACILITIES, AND A MINIMUM OF 5-FEET FOR ALL OTHER UTILITIES (INCLUDING, BUT NOT LIMITED TO, GAS, ELECTRIC, CABLE, AND PHONE).
5. ALL CABLE CONNECTIONS TO STEEL PIPE AND FITTINGS SHALL BE ACCOMPLISHED UTILIZING AN EXOTHERMIC WELDING PROCESS SUCH AS "CALDWELL" BY ERICO PRODUCTS, INC. OR APPROVED EQUAL (SEE W-23B FOR EXOTHERMIC WELD DETAIL). ALL MATERIAL AND EQUIPMENT UTILITIZED FOR WELDING SHALL BE FROM ONE MANUFACTURER.
6. ANODE CABLES SHALL BE CONNECTED DIRECTLY TO FERROUS PIPE OR FITTINGS. LEAD WIRE FOR THE ANODES SHALL BE 30-FEET LONG, #10 AWG SOLID COPPER WIRE WITH BLACK RHW-USE INSULATION. LEAD WIRES SHALL BE SILVER SOLDERED TO ANODE CORE WITH THE CONNECTION ENCAPSULATED IN EPOXY RESIN.
7. ANODE INSTALLATION PROCEDURE SHOWN ABOVE IS TO BE USED AS A GENERAL GUIDE ONLY. CONSULT MANUFACTURER'S LITERATURE FOR SPECIFIC INSTALLATION INSTRUCTIONS.
8. A SOILS ANALYSIS IS REQUIRED FOR ALL NEW WATER MAIN INSTALLATIONS. A SOIL SAMPLE SHALL BE TAKEN EVERY 1000-FT OF NEW PIPE INSTALLATION AT A DEPTH OF 4-FEET. THE SOILS ANALYSIS SHALL INCLUDE CORROSIVITY TESTING. THE CORROSIVITY TESTS SHALL INCLUDE (AT A MINIMUM) CHLORIDES (ASTM D4327), pH (ASTM D4972), RESISTIVITY AT 100%% SATURATION (ASTM G57), SULFATE (ASTM D4327), AND REDOX POTENTIAL (ASTM D1498).
9. QUANTITY, SIZE, AND TYPE OF ANODES REQUIRED FOR NEW WATER FACILITIES SHALL BE DETERMINED BY THE WATER DIVISION AFTER RESULTS OF SOILS ANALYSIS HAVE BEEN REVIEWED BY THE WATER DIVISION.
10. AREAS DETERMINED TO CONTAIN MODERATELY OR HIGHLY CORROSIVE SOILS SHALL REQUIRE INSTALLATION OF A CORROSION TESTING STATION AT 500-FT TO 1000-FT INTERVALS, AS APPROVED BY THE WATER DIVISION. TEST STATIONS SHALL BE INSTALLED UNDER THE DIRECTION AND OBSERVATION OF A CERTIFIED CORROSION SPECIALIST. TEST STATIONS SHALL BE LOCATED ABOVE THE POINT OF CONNECTION ON THE WATER MAIN AND KEPT WITHIN A G5 BOX LABELED "CP TEST" IN THE STREET PAVEMENT SECTION.
11. ANODE SHALL BE INSTALLED LEVEL WITH OR DEEPER THAN THE WATER MAIN IT IS CONNECTED TO, WITH A MINIMUM DEPTH OF 24-INCHES (2-FEET).

CITY OF NAPA

UTILITIES DEPARTMENT

TITLE

ANODE INSTALLATION

DRAWN BY:	DF
APPROVAL DATE:	09/2021
SCALE:	NTS
REVISED DATE:	09/2021

CHECKED BY:	SL
APPROVED BY:	DD
DRAWING NO.	W-24A