

SIDEWALK CONNECTION

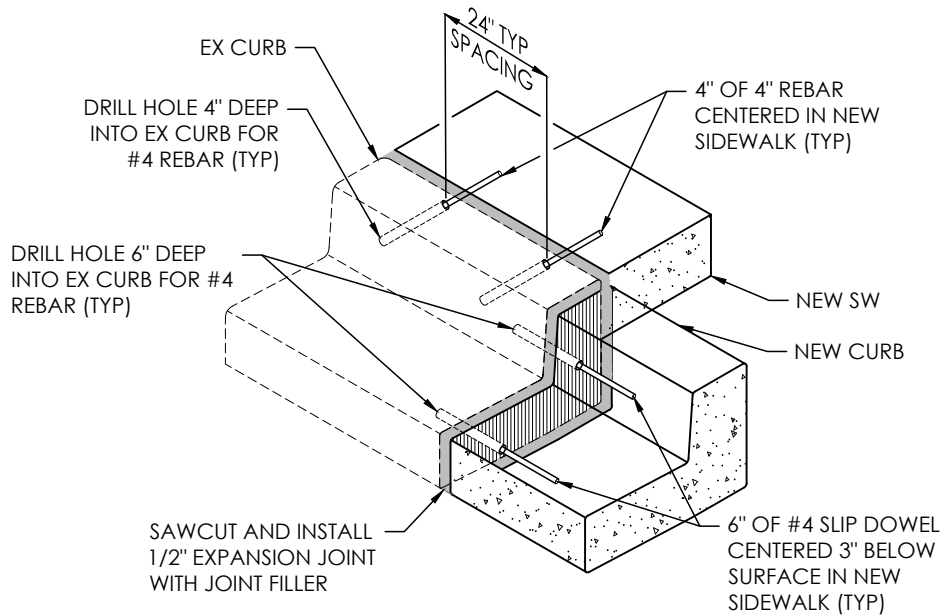

SIDEWALK, CURB AND GUTTER CONNECTION

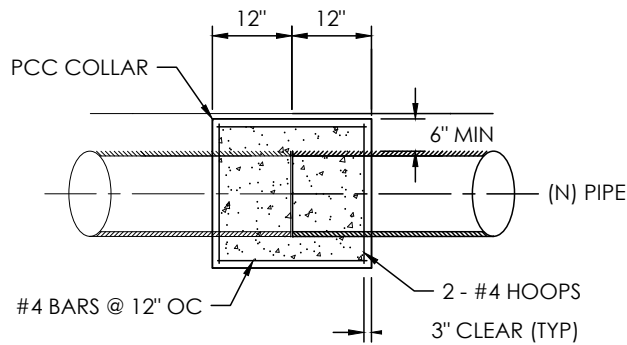

CONCRETE COLLAR CONNECTION

NOTES

1. FOR ALL CURB AND GUTTER CONNECTIONS, ADJUST CURB FACE HEIGHT AS NECESSARY TO MATCH EXISTING CURB

CITY OF NAPA

PUBLIC WORKS DEPARTMENT

CONCRETE CONNECTIONS

DRAWN BY: LFM
 APPROVAL DATE: 06/2018
 SCALE: NONE
 REVISED DATE: 08/2021

CHECKED BY: IHH
 APPROVED BY: JBL
 DRAWING NO. S-4B